

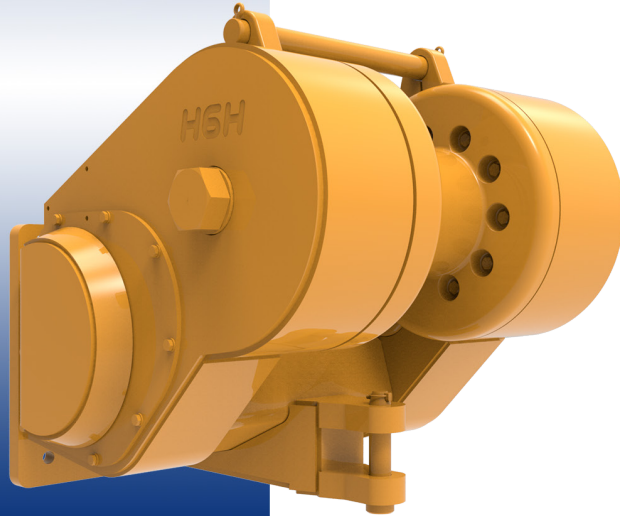

# Operating Manual



## Allied H6H Hydraulic Winch

This manual must be with the vehicle  
on which this winch is installed.

Please check the Allied Systems website  
regularly for updates to this manual.  
[www.alliedsystems.com](http://www.alliedsystems.com)

A PRODUCT OF

**Allied Systems**  
COMPANY

SHERWOOD, OREGON USA

P/N 599038W

7/2018

Winch Model     H6H    

Serial Number \_\_\_\_\_

Date Delivered \_\_\_\_\_

Date Installed \_\_\_\_\_

Special Equipment or Attachments

---

---

---

---

---

---

---

---



A Product of Allied Systems Company  
Sherwood, Oregon USA



7/2018  
Printed in USA

## Foreword

The safe and efficient operation of a winch requires skill and alertness on the part of the operator. To develop the skills required, the operator must:

- Receive training in the proper operation of the winch and the machine on which it is mounted.
- Understand the capabilities and limitations of the winch and the machine on which it is mounted.
- Become familiar with the winch and the machine on which it is mounted and see that they are maintained in good condition.
- Read and understand the SAFETY SUMMARY and OPERATING PROCEDURES contained in this Operating Manual.

In addition, a qualified person experienced in the operation of the winch must guide a new operator through several load handling applications before the new operator attempts to operate the equipment alone. It is the employer's responsibility to make sure that the operator can see, hear, and has the physical and mental ability to operate the equipment safely.

This operating manual contains basic information necessary for the operation and maintenance of a winch. Optional equipment is sometimes installed that can change the characteristics described in this manual. Make sure the necessary instructions are available and understood before operating the winch.

Some of the components described in this Operating Manual will NOT be installed on your winch. If you have questions about any item on your winch or described in this operating manual, contact your local winch dealer, or contact Allied Systems Company:

Allied Systems Company  
21433 SW Oregon Street  
Sherwood, OR 97140 USA

Phone: 503-625-2560

Fax: 503-625-7269

E-Mail: [marketing@alliedsystems.com](mailto:marketing@alliedsystems.com)

Also visit our website, [www.alliedsystems.com](http://www.alliedsystems.com), where the most current copy of this manual is always available.

**Note: For repairs and overhaul, contact your Allied winch dealer. If you maintain your own equipment, a service manual is available for your specific winch.**

**Note: This publication may be translated to different languages for sole purpose of easy reference in non-English speaking locations. Should there be differences in interpretations to the text, please refer to the English language edition published by Allied Systems Company as the controlling document.**

## Contents

|                             |     |
|-----------------------------|-----|
| <b>Foreword</b> .....       | i   |
| <b>Contents</b> .....       | iii |
| <b>Safety Summary</b> ..... | v   |

### General

|                                     |    |
|-------------------------------------|----|
| Introduction .....                  | 1  |
| Operating Principles of Winch ..... | 1  |
| Nameplate .....                     | 3  |
| Wire Rope Selection .....           | 4  |
| Winch Descriptions .....            | 5  |
| Oil Specifications .....            | 6  |
| Oil Capacity .....                  | 6  |
| Serial Number Codes .....           | 7  |
| Optional Equipment .....            | 10 |

### Operation

|                               |    |
|-------------------------------|----|
| Checks Before Operation ..... | 11 |
| Checks During Operation ..... | 11 |
| Operating Procedures .....    | 12 |
| BRAKE-ON & LINE-IN .....      | 12 |
| LINE-OUT .....                | 15 |
| HI-SPEED Operation .....      | 15 |

|                                   |    |
|-----------------------------------|----|
| BRAKE-OFF .....                   | 15 |
| FREESPOOL Operation .....         | 16 |
| FREESPOOL Drag Adjustment .....   | 17 |
| Winch Troubleshooting Chart ..... | 18 |

### Maintenance

|                            |    |
|----------------------------|----|
| Maintenance .....          | 19 |
| Maintenance Points .....   | 19 |
| Maintenance Schedule ..... | 20 |

### Operating Techniques

|   |    |
|---|----|
| Tractor or Skidder Operation .....      | 21 |
| How To Move A Disabled Vehicle .....    | 24 |
| Working on A Steep Slope .....          | 26 |
| Tractor Is Down The Slope .....         | 26 |
| Other Equipment Is Down The Slope ..... | 27 |

### Optional Equipment

|                            |    |
|----------------------------|----|
| Integral Arch .....        | 29 |
| Fairlead .....             | 29 |
| Drawbar .....              | 30 |
| Optional Gear Ratios ..... | 30 |

Intentionally Blank

## Safety Summary

### General Safety Notices

The following pages contain general safety warnings which supplement specific warnings and cautions appearing elsewhere in this manual. All electrical and hydraulic equipment is dangerous. You must thoroughly review and understand the Safety Summary before attempting to operate, troubleshoot or service this winch.

The following symbols/terms are used to emphasize safety precautions and notices in this manual:

 **DANGER**

The “DANGER” symbol indicates a hazardous situation which, if not avoided, will result in death or serious injury. Carefully read the message that follows to prevent serious injury or death.

 **WARNING**

The “WARNING” symbol appears wherever incorrect operating procedures or practices could cause serious injury or death. Carefully read the message that follows to prevent serious injury or death.

 **CAUTION**

The “CAUTION” symbol appears where a hazardous situation which, if not avoided, could result in minor to moderate injury and equipment damage.

## NOTICE

This signal word alerts to a situation that is not related to personal injury but may cause equipment damage.

NOTE: ...

The term “NOTE” highlights operating procedures or practices that may improve equipment reliability and/or personnel performance.

### Safety Regulations

Each country has its own safety legislation. Know and understand these regulations and comply with them in full. This also applies to local bylaws and regulations in force on a particular worksite.

Should the recommendations in this manual deviate from those in the users’ country, the national regulations should be followed.

**NOTE:** All possible safety hazards cannot be foreseen so as to be included in this manual. Therefore, you must always be alert to potential hazards that could endanger personnel and/or damage the equipment.

### Operation, Inspection, and Maintenance Warnings

 **WARNING**

The winch shall not be used for hoisting.

 **WARNING**

Use hearing protection when operating winches.

 **WARNING**

Maximum permissible system pressure and flow: 4250 PSI / 55 GPM.



**Obey the following cautions and warnings before using your winch, to avoid equipment damage, personal injury or death.**

- Do not operate the winch unless you are authorized and trained to do so.
  - Do not operate the winch unless the vehicle is equipped with a screen to protect the operator if the wire rope breaks.
  - Read, understand, and follow the operating, inspection, and maintenance instructions in this Operating Manual.
  - Do not use the control levers for hand holds when entering or leaving the vehicle.
  - Do not permit other people near the control area when you inspect or repair a machine.
  - Never inspect, repair, or perform maintenance on a machine that is in motion.
- Inspect the winch before each use:
    - » Make sure that the controls and instruments operate correctly.
    - » Report the need for repairs immediately.
    - » Do not work with a damaged or worn wire rope.
    - » Do not use a winch that needs repairs.
    - » If the wire rope and ferrule must be removed from the drum, make sure the end of the wire rope and ferrule are controlled when the ferrule is released. The end of the wire rope can suddenly move from the drum like a compressed spring when the ferrule is released and cause an injury.
  - Stay in the operator's seat when operating the winch.
  - Do not stand on the vehicle when operating the winch.
  - Avoid winch operation near people or other machines.

- Never stand nor permit others to stand in the bight (loop) of a wire rope.
- Do not stand nor permit others to be near the winch or wire rope when there is tension on the wire rope.
- Observe jobsite rules.
- Be in complete control at all times.
- Do not use the control levers as hangers for clothes, water bags, grease guns, lunch pails, etc.
- Do not leave the vehicle when the winch wire rope is under tension.
- Do not permit riders on the vehicle or load.
- Do not use the winch as an anchor for a double or two-part line.
- Do not pull the hook through the throat or over the drum, which will cause damage.
- When the winch is not in use, make sure the control lever is in **BRAKE-ON** position and the winch brake is applied.

- Do not use winch as a hoist. Tractor and skidder mounted winches are designed for towing.

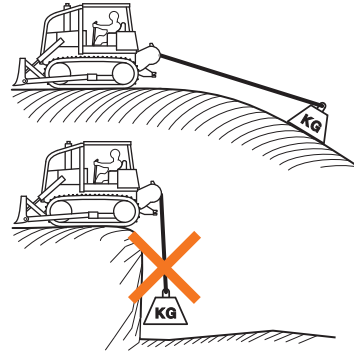

- Always inspect wire rope, tail chain and other rigging components for wear, damage, broken strands or abuse before use.
- Never use wire rope, tail chain or other rigging that is worn-out, damaged or abused.
- Never overload wire rope, tail chain or rigging.

# Safety Summary

- Wire rope and tail chain will fail if worn-out, overloaded, misused, damaged, improperly maintained or abused. Wire rope or tail chain failure may cause serious injury or death!



- Do not terminate wire rope to tail chain by the use of a knot.
- Do not handle wire rope if the hook end is not free. A load could break away, suddenly tensioning the wire rope, resulting in serious injury or death.
- Stay clear of wire rope entry areas (fairlead or arch rollers, winch drum etc).

- Make sure ground personnel are in plain view of the operator, and at a distance of at least 1½ times the working length of the wire rope.
- Make sure that any hand signals used by ground personnel are clearly defined and understood by everyone involved.
- Do not attempt to “jerk” or “shock” a load free. Doing so can cause loads in excess of the rated capacity of the wire rope, winch, or mounting hardware.
- Replace any parts only with genuine Allied Winch parts. Refer to Parts Manual 599039W.
- Maintain **a minimum of three (3) complete wraps of wire rope** on the drum for normal operation. It may help to paint the last five wraps of wire rope a contrasting color, to serve as a visual indicator.
- Do not handle wire rope with bare hands. Wear leather gloves at all times.
- Align the tractor with the load to prevent side loading the winch, and to maintain even spooling of the wire rope.

- If applying tension to the wire rope manually during spooling:
  - » ensure that the operator is winching in slowly,
  - » keep your hands and clothing well clear of any rollers or the winch drum,
  - » do not maintain tension by letting the wire rope to slip through your hands,
  - » use a hand-over-hand technique to maintain tension.
- Be aware of the ground conditions, and make sure the ground and tractor are stable enough to pull the intended load.
- Do not attempt to pull loads in excess of the rated capacity of the winch.
- Keep yourself informed of any applicable codes, regulations and standards for the job.
- Your winch may have temperature shut-off system for protection of tractor and winch. Manual override of high temperature shut-off will cause damage to tractor and winch.
- This winch is neither intended, designed, nor rated for any application involved in the lifting or moving of personnel.
- Use only the lubricants listed in the Oil Specifications. See Page 6.
- Do not weld on any part of the winch. Contact Allied Systems if weld repairs are needed.
- The hydraulic system must be kept clean and free of contamination at all times.
- Be aware of the hazards of pressurized hydraulics:
  - » Wear personal protective equipment, such as gloves and safety glasses, whenever servicing or checking a hydraulic system.
  - » Assume that all hydraulic hoses and components are pressurized. Relieve all hydraulic pressure before disconnecting any hydraulic line.
  - » Never try to stop or check for a hydraulic leak with any part of your body; use a piece of cardboard to check for hydraulic leaks.
  - » Small hydraulic hose leaks are extremely dangerous, and can inject hydraulic oil under the skin, even through gloves.
  - » Infection and gangrene are possible when hydraulic oil penetrates the skin. See a doctor immediately to prevent loss of limb or death.

Notes

---

## Notes

## General

### Introduction

This Operating Manual contains basic information necessary for the operation and maintenance of the H6H winch.

### Operating Principles of Winch

A winch is normally installed on a skidder or tractor to:

- increase the pulling power of the skidder or tractor.
- reach into an area where a skidder or tractor cannot go.
- make lift functions available when special attachments are installed (see page vii).

The winch is powered by an internal hydraulic motor connected to the tractor hydraulic system. Oil flow and pressure are converted to rotational energy by the winch motor. On the H6H, torque is transmitted through a holding brake, a planetary speed reducer and two gear reductions to the drum. Hydraulic oil is supplied by the tractor mounted pump. The winch utilizes oil, filtration

and cooling provided by the tractor circuit. Operation of the winch is controlled by a control lever and electrical switches located at the tractor's control station.

The tractor must be running and the auxiliary hydraulic function switch, if equipped, must be on. **LINE-IN**, **LINE-OUT** and **BRAKE-ON** are controlled by a proportional control lever. When the control lever is in the **BRAKE-ON** or centered position, the holding brake is automatically applied. Pushing the lever away from the operator releases the brake and reels wire rope off the drum (**LINE-OUT**). Pulling the lever towards the operator releases the brake and reels wire rope onto the drum (**LINE-IN**). Releasing the lever causes it to return to the **BRAKE-ON** position, which stops the drum rotation and applies the holding brake. Moving the lever a small amount results in slow wire rope movement for inching control. Line speed increases proportionally as the lever is moved farther.

By moving the control lever to full stroke, **HI-SPEED** is activated. Control pressure actuates the motor swash plate to reduce motor displacement and increase motor rpm. If pressure in the main circuit exceeds a factory set level,

the motor will automatically increase motor displacement to prevent motor stall. Motor stall will occur when the load exceeds winch capacity. When the control lever is returned to the **BRAKE-ON** position, the brake is automatically applied.

The switch panel contains two rocker switches to control **FREESPOOL**, and **BRAKE-OFF**.

The tractor must be running to supply both hydraulic and electrical powers to operate these functions.



## WARNING

**FREESPOOL should not be used if there is a load on the wire rope. An uncontrolled release of the load will occur. Loss of the load can result in equipment damage, personal injury or death.**

The yellow indicator panel on the selector switch lights when the winch is in **FREESPOOL**. The red indicator in the **BRAKE-OFF** switch will also light even though that switch is in the off position.

When **FREESPOOL** is selected, a hydraulically-actuated sleeve disengages the drum pinion from the intermediate shaft. The drum is now disconnected from the brake and the winch cannot support a load. The control lever will still operate the winch motor but the drum will not turn.

When the **BRAKE-OFF** switch is selected, the brake-off clutch is disengaged, allowing the tractor to move away from a towed load. **BRAKE-OFF** is controlled by the rocker switch with a red indicator. A safety lock prevents the switch from accidentally being turned on. To operate the switch, slide the locking tab first, then push the rocker switch.

The **BRAKE-OFF** position is used when there's a load on the winch wire rope. It allows the operator to move the tractor away from the load while spooling wire rope off the drum in a controlled manner.

In **BRAKE-OFF**, hydraulic pressure is applied to release the brake-off clutch. As wire rope is pulled from the winch, the turning drum back-drives the winch gear train to the brake-off clutch. The winch motor, brake, and planetary reducer remain stationary. Mechanical drag through the gear train and viscous drag in the brake-off clutch keep the wire rope from bird-nesting as it is spooled off the drum.



## WARNING

**BRAKE-OFF** should not be used to lower a suspended load or a load that can slide down a slope.

### Nameplate

Each winch is shipped from the factory with a nameplate as shown in Figure 1. The nameplate is stamped with:

- winch model
- winch serial number
- maximum bare drum line pull
- maximum wire rope diameter

DO NOT operate the winch with larger diameter wire rope. If the nameplate is missing, DO NOT operate the winch until its capacity is known.

The serial number for the winch is also stamped into the frame next to the nameplate.



Figure 1 - Nameplate

## Wire Rope Selection

Each winch model can have a variety of wire rope sizes installed by the user. The maximum wire rope size is shown on the nameplate. See Figure 2 for approved wire rope sizes and drum capacities. When a larger diameter wire rope is used, the length of wire rope installed on the drum will be shorter. In some situations, the winch can create a tension in the wire rope that is greater than the strength of the wire rope. The user must be careful to select a wire rope that has enough strength and length for the job.



### WARNING

**During operation of the winch, the operator must know or estimate the line pull and make sure that the line pull is within the capacity of the winch and the specifications of the wire rope installed on the drum. A broken wire rope under high tension can return suddenly in the direction of the winch and cause equipment damage, injury or death.**

The wire rope may disengage from the ferrule

**pocket if there is a load on the wire rope with fewer than 3 complete wraps on the drum. This will cause a loss of load and possible injury. When spooling wire rope from the drum, it is very difficult for the operator to know when nearing the end of the wire rope. It is recommended that the last 5 wraps of wire rope be painted a contrasting color to alert the operator that the end of the usable wire rope has been reached.**

| Wire Rope Diameter | Capacity (Drum: 10 in.) |
|--------------------|-------------------------|
| 19mm (3/4 in.)     | 126 m (413 ft.)         |
| 22mm (7/8 in.)     | 91 m (297 ft.)          |
| 25mm (1.0 in.)*    | 70 m (230 ft.)          |

Notes:

- Loosely or unevenly spooled line will change capacities.
- Use flexible wire rope with independent wire rope center.
- Ferule size: 2.0 in dia, 2 1/4 in long.

\* If your winch is equipped with the optional arch, the largest wire rope diameter approved for use is 7/8 inch.

**Figure 2 - Drum Line Capacities**

|  |
|--|
| <b>Ferrule Size &amp; Type</b><br>Light Ferrule 2 1/4" x 2.0" Dia. |
|--|

**Figure 3 - Ferrule Size and Type**

## Winch Descriptions

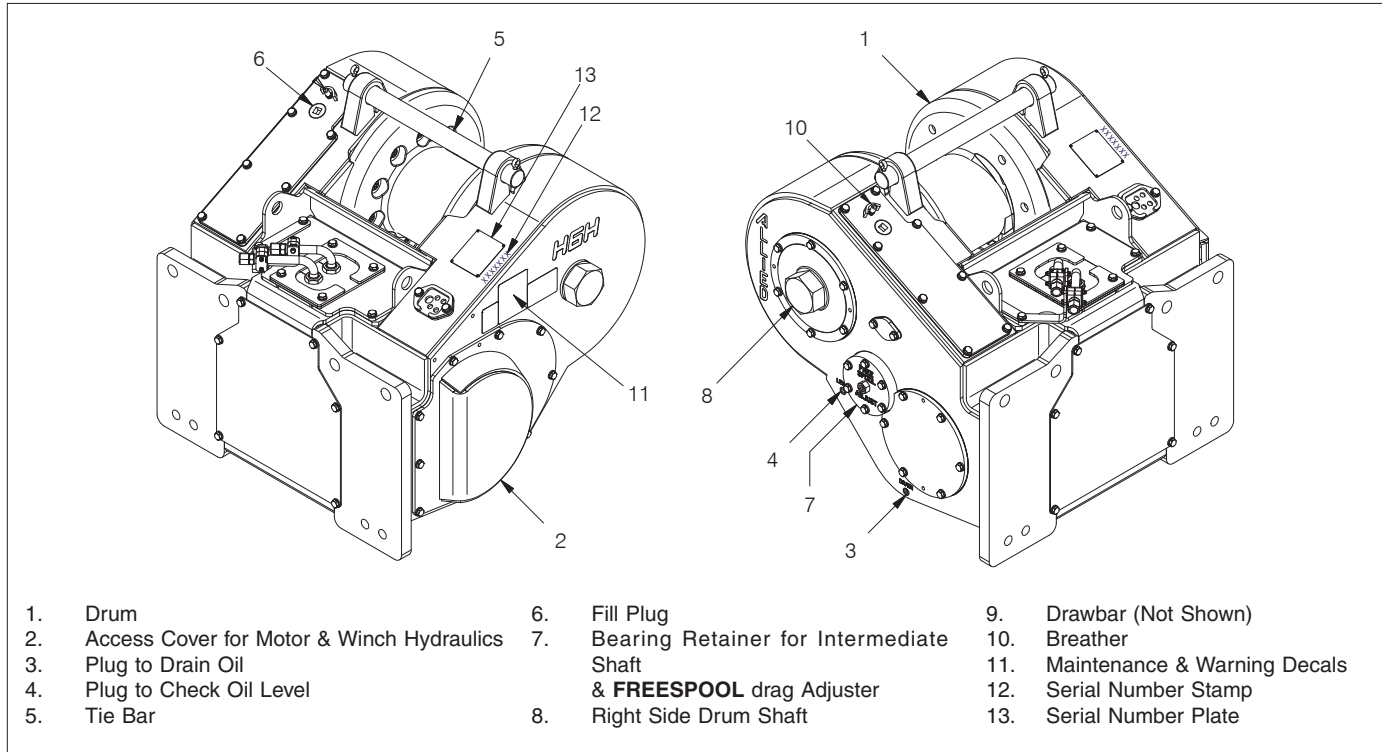

Figure 4 - H6H Towing Winch



## Oil Specifications

The hydraulic winch motor and control system operate off of the tractor implement hydraulic system. The winch gear case is filled with hydraulic transmission oil and is separate from the tractor hydraulic system. Factory fill for the gear case is oil meeting Caterpillar TO-4 specification SAE 30 weight. For proper operation of the BRAKE-OFF clutch, only oils meeting this specification should be used in the winch gear case.

Other hydraulic oils meeting this specification are:

ExxonMobil, Mobiltrans HD-30

Chevron, Chevron Drive Train Fluid HD SAE 30.

## Oil Capacity

The oil capacity for H6H winch is 4 gallons (15 liters).

## Serial Number Codes

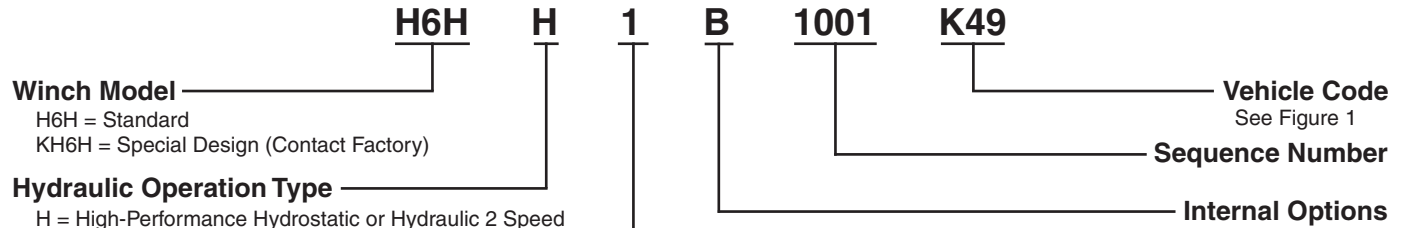

- Notes:**
1. In addition to the serial number plate, the serial number is stamped on the top left-hand side of the frame.
  2. Circled numbers in Figure 5 indicate possible gear ratios.

|    | PFR | FREESPOOL | BRAKE-OFF | OVERWIND | 2-SPEED CONTROL |
|----|-----|-----------|-----------|----------|-----------------|
| B  | X   | X         | X         | X        |                 |
| D  | X   | X         | X         | X        | X               |
| E  | X   | X         |           | X        |                 |
| U  | X   | X         | X         |          |                 |
| BN | X   |           | X         | X        |                 |
| DN | X   |           | X         | X        | X               |
| EN | X   |           |           | X        |                 |
| DE | X   | X         |           | X        | X               |
| DU | X   | X         | X         |          | X               |

### Tractor Make Model and Starting Tractor Serial Number Where Applicable

| C<br>O<br>D<br>E | <b>C</b><br>Caterpillar | <b>E</b><br>John Deere          | <b>H</b><br>Dressta | <b>K</b><br>Komatsu | <b>L</b><br>Liebherr | <b>P</b><br>Caterpillar-SEM | <b>R</b><br>Case     | <b>U</b><br>Shantui | <b>Y</b><br>Tigercat |
|------------------|-------------------------|---------------------------------|---------------------|---------------------|----------------------|-----------------------------|----------------------|---------------------|----------------------|
| <b>39</b>        |                         |                                 | TD14/15/16S<br>①    |                     | PR716 ⑤ ⑥            |                             |                      |                     |                      |
| <b>391</b>       |                         |                                 |                     |                     |                      |                             | Steiger<br>⑥         |                     |                      |
| <b>40</b>        |                         |                                 |                     |                     |                      |                             | 1650L ①              |                     |                      |
| <b>41</b>        |                         |                                 |                     |                     | PR724 ⑤ ⑥            |                             |                      |                     |                      |
| <b>410</b>       |                         |                                 |                     |                     | PR726 ⑤ ⑥            |                             |                      |                     |                      |
| <b>42</b>        |                         |                                 |                     |                     | PR736 ①              |                             | 1650M/<br>2050M<br>① |                     |                      |
| <b>421</b>       |                         |                                 |                     |                     | PR736 ①              |                             |                      |                     |                      |
| <b>44</b>        |                         |                                 |                     |                     | PR734-4 ⑥            |                             |                      |                     | 635D ②               |
| <b>46</b>        |                         |                                 |                     | D65-15 ⑥            |                      |                             |                      |                     |                      |
| <b>460</b>       |                         | 750/850J &<br>750/850K ①        |                     |                     |                      |                             |                      |                     |                      |
| <b>465</b>       |                         | 750/850K with<br>E/H Controls ① |                     |                     |                      |                             |                      |                     |                      |

**Figure 5 - Tractor Identification Codes and Available Gear Ratios for H6H Winch (1)**

## Tractor Make Model and Starting Tractor Serial Number Where Applicable

| <b>C<br/>O<br/>D<br/>E</b> | <b>C</b><br>Caterpillar | <b>E</b><br>John Deere | <b>H</b><br>Dressta | <b>K</b><br>Komatsu              | <b>L</b><br>Liebherr | <b>P</b><br>Caterpillar-SEM | <b>R</b><br>Case | <b>U</b><br>Shantui | <b>Y</b><br>Tigercat |
|----------------------------|-------------------------|------------------------|---------------------|----------------------------------|----------------------|-----------------------------|------------------|---------------------|----------------------|
| <b>47</b>                  |                         | Replaced by<br>E460    |                     |                                  |                      |                             |                  | DH17 ⑥              |                      |
| <b>471</b>                 |                         |                        |                     | D61-23 ②                         |                      |                             |                  |                     |                      |
| <b>48</b>                  |                         | Replaced by<br>E460    |                     |                                  |                      |                             |                  |                     |                      |
| <b>49</b>                  |                         |                        |                     | D65-16, D65-<br>17 & D65-18<br>① |                      |                             |                  |                     |                      |
| <b>71</b>                  | D6T ⑥                   |                        |                     |                                  |                      |                             |                  |                     |                      |
| <b>81</b>                  | D6N ①                   |                        |                     |                                  |                      | 816/822 ⑥                   |                  |                     |                      |
| <b>811</b>                 | D6N* ①                  |                        |                     |                                  |                      |                             |                  |                     |                      |
| <b>963</b>                 | 963D Track<br>Loader ①  |                        |                     |                                  |                      |                             |                  |                     |                      |
| <b>973</b>                 |                         |                        |                     |                                  |                      |                             |                  |                     |                      |

\* Serial numbers with prefixes GHS, MLW & LJR: \_\_\_\_\_

Figure 5 - Tractor Identification Codes and Available Gear Ratios for H6H Winch (2)

## Optional Equipment

The H6H winches may be equipped with the following options:

- Integral arch
- Fairlead assembly
- Heavy duty extended drawbar
- Optional gear ratios

**NOTE: Not all optional equipment listed is available for each model of tractor.**

\* See the nameplate for the max wire rope size with arch.

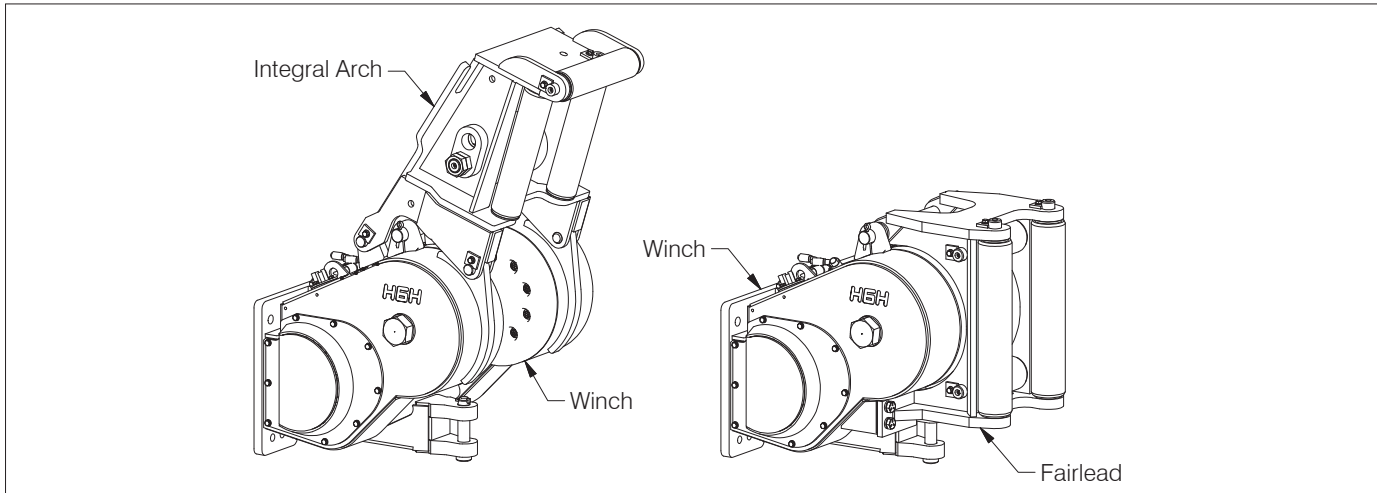

**Figure 6 - Integral Arch and Fairlead for H6H Winch**

## Operation

### Checks Before Operation

Check the wire rope and hook for wear or damage. Check that the periodic inspection and maintenance have been done at the recommended operating hours. See Figure 11, the Maintenance Schedule, on page 20.

### Checks During Operation

The Troubleshooting Chart, Figure 9 on page 18, can be used by the operator to identify a problem with the winch operation. A trained service person is needed for additional troubleshooting and repair that requires disassembly of parts of the winch.

## Operating Procedures

The H6H winch is designed to operate on a load sense, pilot operated hydraulic system. When the tractor is running, and the auxiliary hydraulic function switch, if equipped, is on, the winch is ready to operate, but no oil is flowing to the winch. Pilot pressure is present at the winch.

The control lever and electrical switches are used to select the following operations (not all winches are equipped with all options):

- **BRAKE-ON** (spring-centered position)
- **LINE-IN**
- **LINE-OUT**
- **HI-SPEED** (Internal Option Code D)
- **BRAKE-OFF**
- **FREESPOOL**

The operator must reset the switches to deactivate the **FREESPOOL** and **BRAKE-OFF** functions.

## BRAKE-ON & LINE-IN

The tractor-mounted lever controls **LINE-IN**, **LINE-OUT** and **BRAKE-ON** functions. When the lever is in the neutral or spring-centered position, the winch is in **BRAKE-ON** mode. In the **BRAKE-ON** position, no oil is directed to the motor, and the spring-applied holding brake prevents drum movement, unless **BRAKE-OFF** or **FREESPOOL** are selected.

Moving the lever directs a pilot signal to the directional control valve, which in turn controls oil flow to the hydraulic winch motor. Pilot pressure is sequenced to release the holding brake as the directional valve begins supplying flow to the motor. Moving the lever toward the operator causes the drum to begin turning and reeling in wire rope.

Hydraulic supply to the winch motor is controlled in proportion to the amount the control lever is moved. Moving the lever a small amount turns the drum slowly; the speed increases as the lever is moved further. Gradually releasing the lever slows the line speed until the drum stops. When the drum stops, the brake is automatically set. Inching control of the line can be achieved by small movements of the lever.

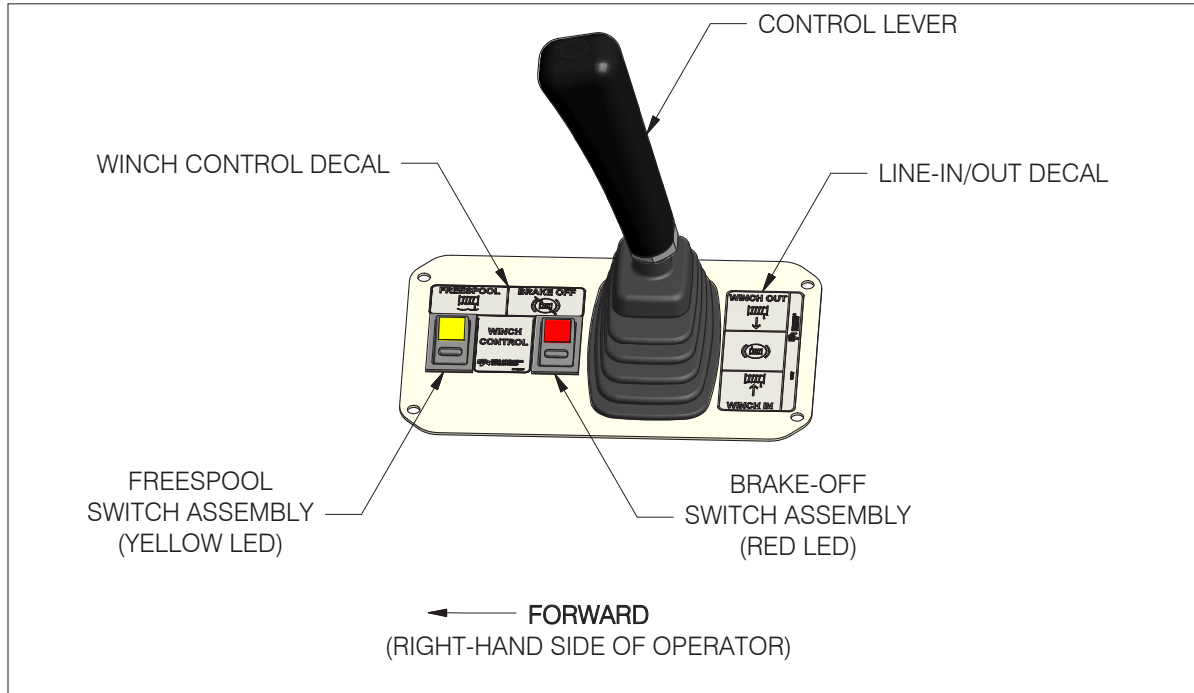

**Figure 7 - H6H Winch Operator Controls**  
(Komatsu D65-16/17/18 - Vehicle Code K49 Shown)

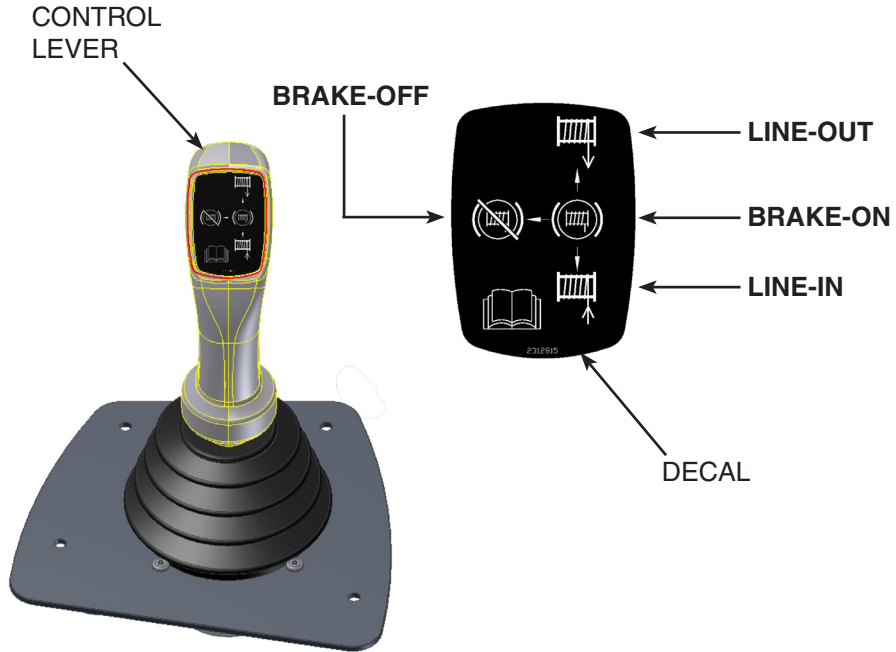

**Figure 7.1 - H6H Winch Operator Controls**  
(Case Steiger - Vehicle Code R391 Shown)

## LINE-OUT

**LINE-OUT** is controlled in the same manner as **LINE-IN**, except the lever is moved away from the operator. **LINE-OUT** speed is also proportional to lever movement. When the lever is returned to the **BRAKE-ON** position, the brake is automatically applied.

## HI-SPEED Operation (Option Code D)

Winches with option code D employ a switch to select **HI-SPEED**.

Selecting **HI-SPEED** commands the winch motor to operate in minimum displacement position to achieve the fastest speed. When activated, a green LED indicator on the switch will be lit. If a load is large enough, the motor will automatically increase displacement to optimize available power.

When better control is desired, the winch should be operated in the normal speed mode. For faster wire rope speed, the winch should be operated in **HI-SPEED** mode.

On certain applications, winches with internal option code D have a **HIGH OIL TEMPERATURE** warning light at the operator console. If hydraulic oil temperature in the winch reaches an unsafe level, the light comes on to warn that continued operation will cause damage to the winch. Winch operation should be curtailed until the oil temperature drops to a safe operating level.

Normal winch operation should not cause overheating, but a high duty cycle or continuous heavy operation may generate more heat than the tractor cooling system can handle. Contact the Allied Service Department for additional information.

## BRAKE-OFF



## WARNING

**BRAKE-OFF should not be used to lower a suspended load or a load that can slide down a slope.**



## WARNING

If the operator leaves the winch in **BRAKE-OFF** mode, the **LINE-IN** and **LINE-OUT** control of the winch will still operate. However, the holding brake is locked out and the winch will not hold a suspended load or a load that can slide away.

**BRAKE-OFF** is controlled by the rocker switch with a red indicator. A safety lock prevents the switch from being accidentally turned on. To operate the switch, slide the locking tab first, then push the rocker switch.

The **BRAKE-OFF** position is used when there's a load on the wire rope. It allows the operator to move the tractor away from the load yet still keep the wire rope tight.

In **BRAKE-OFF**, hydraulic pressure is applied to release the brake-off clutch.

- **Case Steiger (R391)**

**BRAKE-OFF** is controlled by moving the control lever to the left. This function is spring centered to **BRAKE-ON** position, but if the control lever is moved far enough it locks into a detented position.

## FREESPOOL Operation



## WARNING

The winch motor will activate if the lever is moved, but the drum will not be in control.



## WARNING

**Freespool should not be used if there is a load on the wire rope. An uncontrolled release of the load will occur. Loss of the load can result in injury and/or equipment damage.**

**FREESPOOL** is controlled by the rocker switch with a yellow indicator. A safety lock prevents the switch from being accidentally turned on. To operate the switch, slide the locking tab first, then push the rocker switch.

**FREESPOOL** mechanically disengages the winch drum from the drive train so wire rope can be pulled from the winch by hand. It also releases the brake-off clutch to allow re-engagement of the gear train when **FREESPOOL** is turned off. When the **FREESPOOL**

switch is turned on, the yellow indicator will light (as well as the red indicator on the brake-off switch). This is because the brake-off clutch is also released in **FREESPOOL** mode.

**FREESPOOL** must be disengaged by the operator or it will stay on. Turn the switch off to disengage.

## **FREESPOOL Drag Adjustment**

The preload on the bearings of the intermediate shaft controls the resistance to rotation of the drum during the **FREESPOOL** operation. The resistance to rotation is correct when the drum can be rotated by hand, but the drum will not rotate more than one-half revolution freely.

An adjusting screw is located in the center of the bearing retainer for the intermediate shaft; please refer to Figure 8. This screw can be tightened or loosened to adjust the preload on the intermediate shaft. The jam nut will maintain the **FREESPOOL** setting.



**Figure 8 - FREESPOOL Adjustments**

## **CAUTION**

Setting the preload on the intermediate shaft too tight will cause bearing overload. Setting the preload too loose will allow shaft to not be parallel. Extreme care must be used when adjusting **FREESPOOL** drag. Determine the correct preload by starting with the preload too loose, and gradually increase the preload until the correct resistance to rotation is achieved (see above). Increase the preload by turning the adjusting screw by a maximum of 1/6 rotation (60 degrees), and striking the housing with a hammer to make sure the bearing is sliding. Check resistance to rotation after each adjustment.

## Troubleshooting Chart

| PROBLEM  | POSSIBLE CAUSE                                    | CORRECTION   |
|--|---|--|
| Operation is rough or not regular.                       | Hydraulic oil is too cold.                        | Allow tractor hydraulics to warm up.               |
|  | Low oil level.                                    | Add oil.   |
| Hydraulic oil becomes too hot.                           | Winch is operated for long periods.               | Allow unit to rest.                                |
|  | Low oil level.                                    | Add oil.   |
| Brake begins to release before the motor moves the drum. | Brake is worn or needs replacement.               | See the Service Manual for additional information. |
|  | Brake valve is out of adjustment.                 |  |
| Winch brake does not apply or release correctly.         | Brake is worn.                                    | See the Service Manual for additional information. |
|  | Brake valve is out of adjustment or low pressure. |  |
| <b>FREESPOOL</b> does not operate correctly.             | Low pressure.                                     | See the Service Manual for additional information. |
|  | Load on wire rope.                                |  |
| <b>BRAKE-OFF</b> does not operate correctly              | Low pressure.                                     | See the Service Manual for additional information. |
|  | Load on wire rope                                 |  |
| Oil is coming out of the breather                        | Leak in <b>FREESPOOL</b> hose or shift fork       | See the Service Manual for additional information. |

Figure 9 - Troubleshooting Analysis Chart

## Maintenance

The Maintenance Schedule is a program that includes periodic inspection and lubrication. Use the operating

time on the hour meter of the tractor to find the maintenance time for the winch.

### Maintenance Points

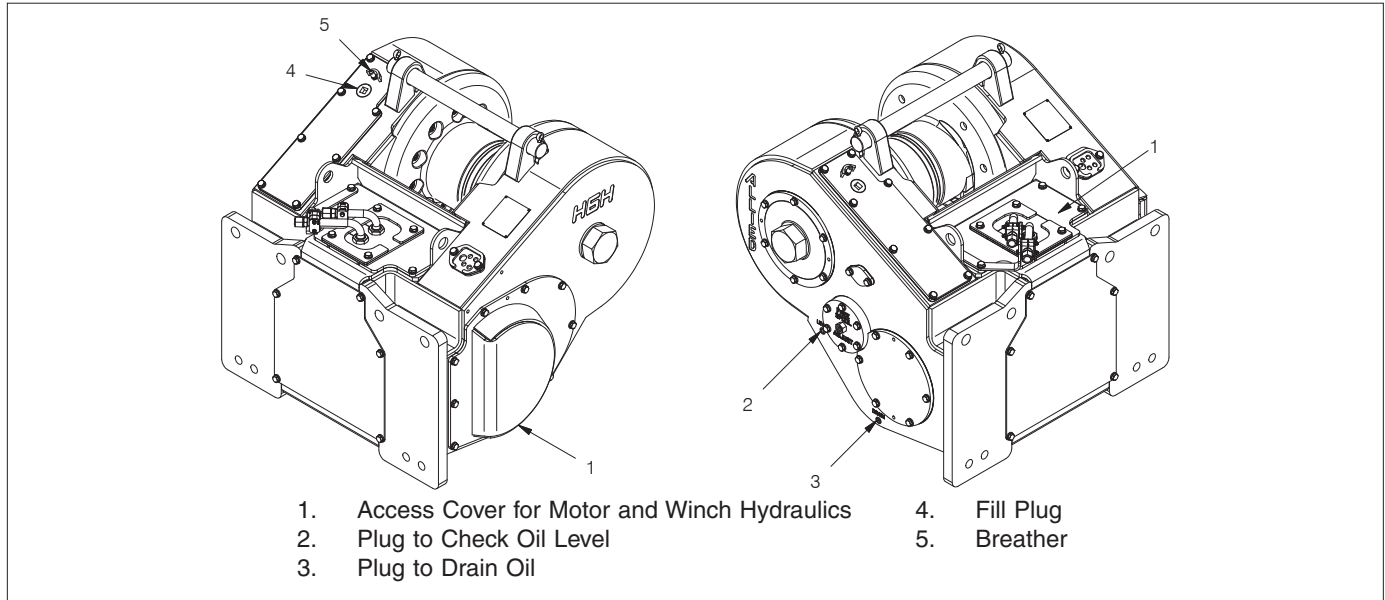

Figure 10 - H6H Winch Maintenance Points



## Maintenance Schedule

| INTERVAL                      | PROCEDURE OR QUANTITY   | SPECIFICATION  |
|-------------------------------|---|--|
| 50 hours or weekly            | Check oil level at plug (item 2). Add oil as necessary through fill plug (item 4). (See Figure 10). <b>Do not operate winch when checking the oil level. If oil level increases, see Troubleshooting Chart.</b> | See Oil Selection and Oil Capacity for details.                              |
|                               | Clean the breather (item 5).  | Remove debris around breather. Clean the breather with solvent if necessary. |
|                               | Lubricate the rollers on the integral arch or the fairlead assembly, if the winch is equipped with either of these options.   | Use multi-purpose grease with 2-4% molybdenum disulfide.                     |
|                               | Inspect safety locking switch for proper operation.   | Switch should not depress without activation of slide-lock.                  |
| 2000 hours or every 12 months | Change the gear oil. Drain oil from plug (item 3). Add 8 liters (8.5 quarts) through fill plug (item 4). Check the oil level at oil level check plug (item 2).  | See Oil Selection and Oil Capacity for details.                              |

Figure 11 - Maintenance Schedule

## Operating Techniques

### Tractor Operation

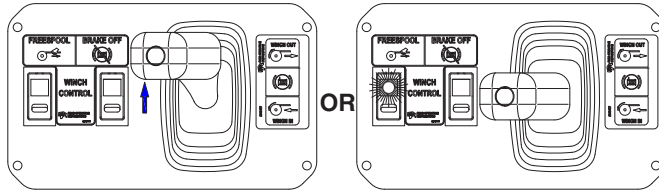

(Solid Arrow indicates lever travel direction)

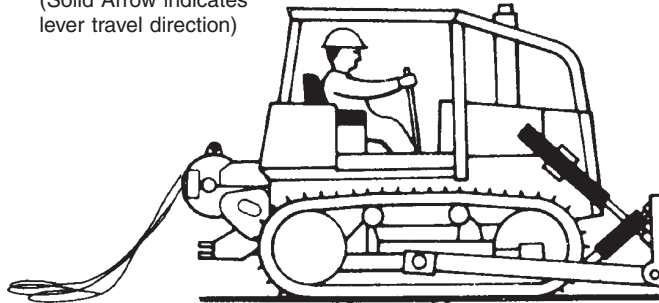

**Step 1.** The tractor or skidder is moved to an area where a load will be connected. The operator moves the control lever to the **LINE-OUT** position or activates the **FREESPOOL** switch so that the wire rope can be pulled from the winch drum.

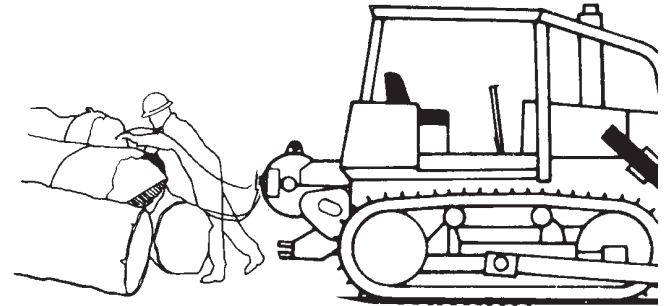
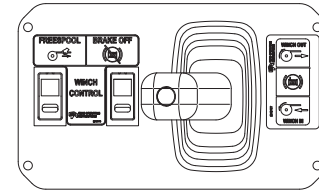

**Step 2.** A load (logs) is connected to the wire rope. If **FREESPOOL** was used, the operator must deactivate the **FREESPOOL** switch.

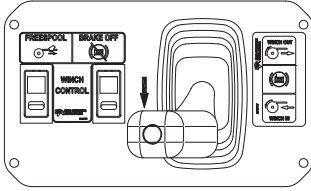

(Solid Arrow indicates lever travel direction)

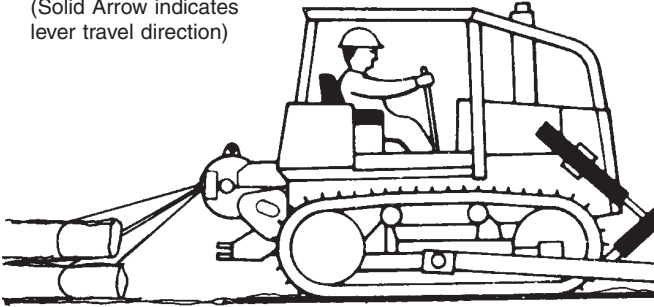

**Step 3.** The operator can move the control lever to the **LINE-IN** position. If the load is less than approximately 50% of the maximum line pull, the operator can begin traveling with the vehicle at the same time. The winch will wind the load toward the vehicle as it travels. If the load is nearly the capacity of the line pull, the operator must move the load close to the vehicle before beginning to travel.

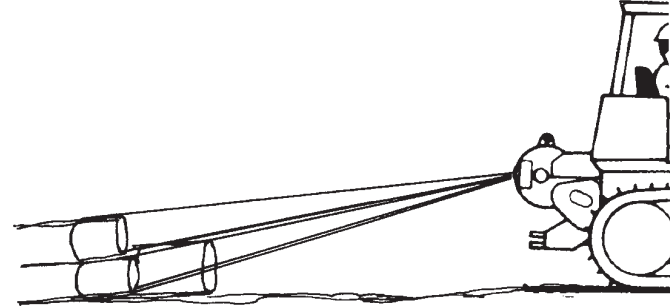
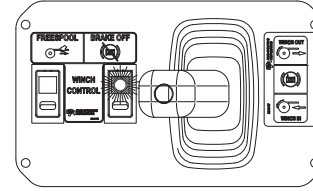

**Step 4.** If the tractor or skidder must travel through an area with bad traction conditions, the operator can activate the **BRAKE-OFF** switch. This will permit the vehicle to move slowly through the bad traction area without pulling the load at the same time.

# Operating Techniques

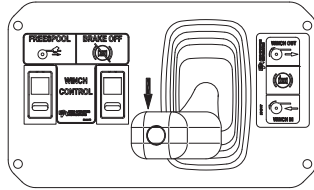

(Solid Arrow indicates lever travel direction)

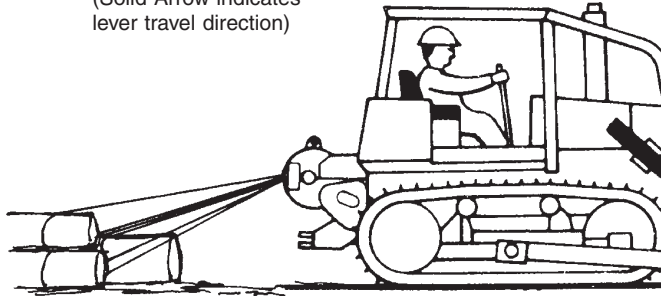

**Step 5.** When the vehicle is on firm ground, the operator can deactivate the **BRAKE-OFF** switch and move the control lever to **LINE-IN** to pull the load toward the vehicle.

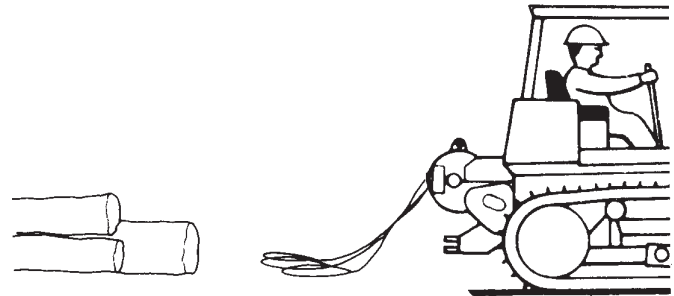
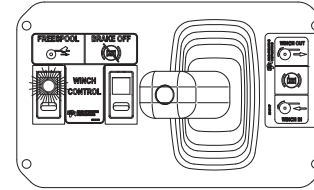

**Step 6.** When the operator wants to disconnect from the load, the vehicle is stopped and the **FREESPOOL** switch is activated to loosen the wire rope. The wire rope is then disconnected from the load.

## How to Move a Disabled Vehicle

**A.** A tractor or skidder often travels in areas where traction conditions are bad. A vehicle equipped with a winch can be used to remove itself from mud or other areas where it cannot move using only the drive wheels or tracks. See Figure 12. Use the following procedure:

1. Fasten the wire rope to a structure, tow bar of another vehicle, or a tree that has enough strength for the line pull. The wire rope must be in a direction that is approximately parallel to the direction of travel of the vehicle.
2. Use the throttle to set the engine speed at a power level to operate both the winch and the tracks or drive wheels. (Operator experience is required, because the winch can use most of the engine power in some vehicles.)

3. Put the control lever in the **LINE-IN** position to tighten the wire rope. When the wire rope is tight, put the vehicle transmission in **REVERSE** and engage the tracks or drive wheels. Use the power from the engine to the winch and tracks together to remove the vehicle from the bad area.
4. If the vehicle travels faster than the winch winds the wire rope, disengage the transmission until the wire rope is tightened again. Do not drive over the wire rope.

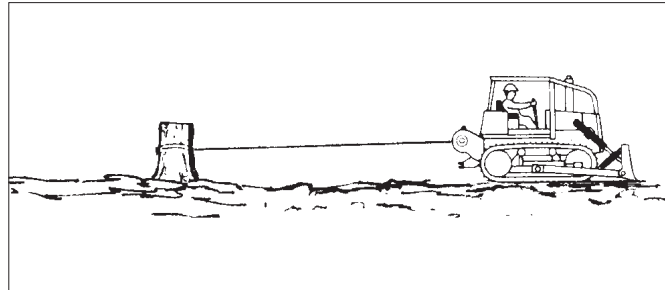

Figure 12 - Moving a Disabled Vehicle (Step A)

# Operating Techniques

**B.** A tractor or skidder equipped with a winch can be used to pull another vehicle from mud or other areas where it cannot move using only the drive wheels or tracks. See Figure 13. Use the following procedure:



## WARNING

**Use extra care if traction conditions are bad or if the vehicles are on a slope. Bad traction can cause the disabled vehicle or the tractor to slide. A slope can require additional distance to stop the vehicles.**

**Ensure the wire rope and tow chain have the capacity to do the job. If the disabled vehicle does not have a tow pin or other equipment for towing, carefully fasten the tow chain around the axle of the disabled vehicle. Make sure the tow chain is fastened so that the chain will not injure people or damage the vehicle.**

**An operator must be on the disabled vehicle to operate the steering and brakes when it is towed.**

1. Fasten the wire rope to the tow bar of the other vehicle. The wire rope must be in a direction that is approximately parallel to the direction of travel of the vehicle. Apply the brakes on the tractor or skidder. Use the throttle to set the engine speed at a power level to operate the winch. (Operator experience is required, because the winch can use most of the engine power in some vehicles.)
2. Put the control lever in the **LINE-IN** position to tighten the wire rope. When the wire rope is tight, use the power from the engine to the winch to pull the vehicle from the bad area. If the disabled vehicle moves under its own power, keep the towing wire rope tight so that the wire rope does not pass under the drive wheels or tracks of the vehicle being towed.

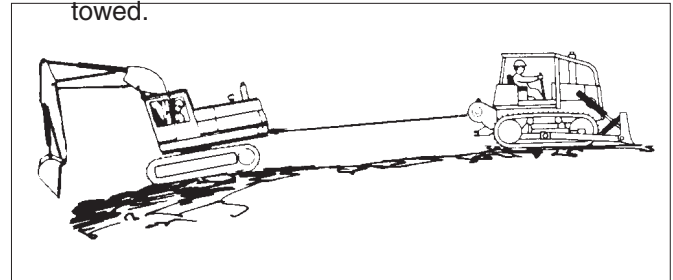

Figure 13 - Moving a Disabled Vehicle (Step B)

## Working on a Steep Slope



### WARNING

The winch and the tractor must be in good condition for the following procedures. Make sure that the required maintenance has been done on the tractor and winch. Use only a wire rope that is in good condition. Make sure the wire rope and winch have enough capacity for the load. Make sure the anchor for the wire rope has enough capacity for the load. A failure of the tractor, winch, or wire rope while working on a steep slope can cause death or injury and loss of equipment.

### Tractor is Down the Slope (See Figure 14).

Sometimes a tractor must work on a steep slope and can use a winch to give assistance when moving on the slope. Fasten the wire rope to the drawbar of another tractor, a structure or a tree that has enough strength to hold the tractor on the slope.

### A. Moving down the slope:

1. Set the throttle on the tractor for the required engine speed.
2. Put the tractor in **FORWARD**. At the same time, move the winch control lever to a position between **BRAKE-ON** and **LINE-OUT** (inching) to control the speed of the tractor down the slope.

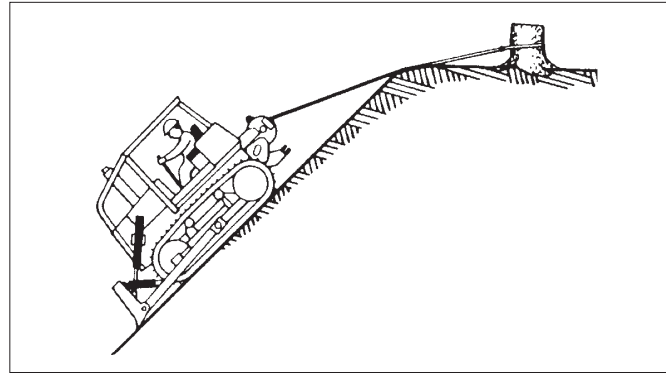

Figure 14 - Working on a Steep Slope

# Operating Techniques

## B. Moving up the slope:

1. Set the throttle on the tractor for the required engine speed.
2. Put the lever in **LINE-IN** position to tighten the wire rope. When the wire rope is tight, put the tractor transmission in the **FIRST** speed range and **REVERSE** and engage the tracks or drive wheels. At the same time, move the control lever on the winch to **LINE-IN**.
3. Use the steering on the tractor to keep the travel of the tractor in line with the wire rope.
4. Engage **LINE-IN** as necessary. Do not permit the wire rope to loosen and pass under the drive wheels or tracks of the tractor.

## Other Equipment is Down the Slope (See Figure 15).

In this operation, the tractor and winch are on stable ground and other equipment is working on a steep slope. The winch is used to give additional control to the equipment working on the steep slope. A winch with a fairlead option is recommended for this operation if alignment of the other equipment with the winch and tractor is a problem.

Make sure the tractor and winch are on stable ground and will not slide when the load is applied. Align the tractor and winch with the load. Apply the parking brake on the tractor.

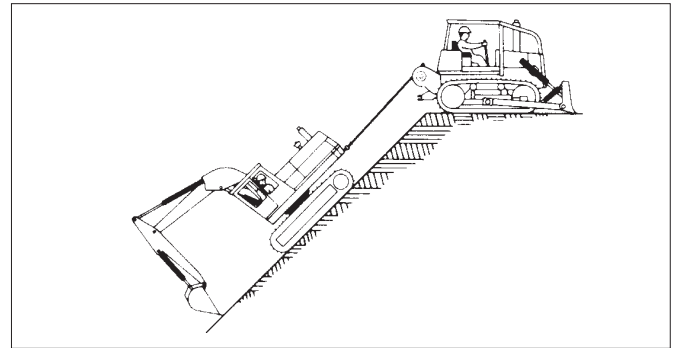

Figure 15 - Other Equipment on a Steep Slope

**A.** Lowering the equipment on the slope:

1. Set the throttle on the tractor for the required engine speed. Operator experience is required for this operation so that the load is carefully controlled.
2. Keep the wire rope tightened between the tractor and the equipment being lowered down the slope. Use the control lever in the **LINE-OUT** position to control the lowering of the equipment down the slope.
3. Move the control lever between **LINE-OUT** and **BRAKE-ON** if inching is required.

**B.** Raising the equipment on the slope:

1. Set the throttle on the tractor for the required engine speed. Operator experience is required for this operation so that the load is carefully controlled.
2. Keep the wire rope tightened between the tractor and the equipment being raised up the slope. Use the control lever in the **LINE-IN** position to control the raising of the equipment up the slope.
3. Move the control lever between **LINE-IN** and **BRAKE-ON** if inching is required.
4. Keep the equipment being raised in alignment with the winch and tractor. Do not permit the wire rope to loosen and pass under the drive wheels or tracks of the tractor.

## Optional Equipment

### Integral Arch

When using an integral arch, the wire rope is routed over a raised horizontal roller and through a set of smaller vertical side rollers and an upper horizontal roller. This enables the winch to pull upwards versus horizontally on loads. In this way, the load can be lifted slightly to reduce drag due to ground contact. The side and top rollers act as fairleads to protect the wire rope from damage and from damaging the frame.

Because the line of action of the wire is higher than normal, the tipping moment applied to the tractor is increased, and the tractor will tip backwards at significantly lower line pulls. The operator must exercise care to not pull more than the tractor can handle stably, especially on side slopes.

Line pulls through the arch also exert higher loads on the fasteners holding the winch to the tractor. For this reason, the wire rope diameter is limited. Refer to tag, manual, or consult the factory.

### Fairlead

A fairlead consists of a set of top and bottom horizontal rollers and side rollers that the wire rope is fed through. With this attachment, if the direction of line pull is not directly behind the fairlead rollers instead of across the frame, thus protecting both the frame and the wire rope from excessive wear.

Stability of the tractor is affected somewhat by the fact that the fairlead rollers are more rearward than the drum, thus putting slightly more moment on the tractor during side pulls. The operator must take care to assure stability on slopes.

## Drawbar

Do not use the drawbar as an anchor point for a multipoint (over puller) line from the winch. Loads applied to the drawbar are transmitted to the bolts holding the winch to the tractor. Standard integral drawbars are designed to handle pulls of 66% of winch rated capacity; bolt on drawbars are 60%. Optional heavy duty and extended drawbars are available which increase the capacity of the drawbar and/or move the pin farther back so it is not under the winch drum.

## Optional Gear Ratios

Lower speed ratios allow better operator control of line speed. They may also allow the winch to pull in excess of wire rope or winch rated capacity. They do not increase the durability or damaging load limit of the winch. Line pulls in excess of rated capacity will dramatically reduce the life of winch components.

Notes

---

## Notes

# NO MATTER HOW YOU SAY IT ...

La Prudence Paye  
La Seguridad Paga  
Betriebssicherheit Macht Sich Bezahlt  
Passaa Olla Huolellinen  
Veiligheid Voor Alles  
Säkerhet Först  
Essere Sicuro Paga  
Segurança Paga  
Sikkerhet Først  
Pinter Be Awas

सावधान और रिटा रहौ ।

في التآني السرمة

安全第一



# SAFETY PAYS!

*SAFETY PAYS!*



To find a dealer in your area,  
Call: 503.625.2560,  
Fax: 503.625.7269, or  
Email: [marketing@alliedsystems.com](mailto:marketing@alliedsystems.com), or  
Visit our website: [www.alliedsystems.com](http://www.alliedsystems.com)

**Allied Systems**  
COMPANY

599038W 7/2018

Printed in USA